

Wiring Diagram/接线图

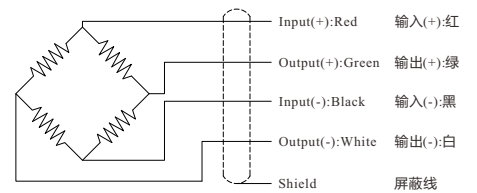

Ordering code
FTHB-10NM
Model Capacity

P-1/2

--- Specifications / 规格参数 ---

Capacity/量程	5/10/15 NM (Customizable)		
Rated Output 额定输出	1.0 mV/V	Compensated Temp. 温度补偿范围	-10...+40°C
Excitation 激励电压	3~12V	Operating Temp. 工作温度范围	-20...+60°C
Zero Balance 零点输出	±3% of R.O.	Temp. Shift Zero 零点温度漂移	±0.02% of R.O./°C
Nonlinearity 非线性	±0.3% of R.O.	Temp. Shift Span 灵敏度温度漂移	±0.01% of R.O./°C
Hysteresis 滞后	±0.3% of R.O.	Input Resistance 输入阻抗	380±30Ω
Nonrepeatability 非重复性	±0.1% of R.O.	Output Resistance 输出阻抗	350±5Ω
Creep(10min) 蠕变(10min)	±0.1% of R.O.	Insulation Resistance 绝缘阻抗	>2000MΩ(50V)
Safe Overload 安全过载	150% of F.S.	Ingress Protection 防护等级	IP60
Ultimate Overload 极限过载	200% of F.S.	Material of Element 弹性体材料	Stainless steel 不锈钢
Cable 导线	Ø3.2*3000mm 4-core shielded cable Ø3.2*3000mm 4芯屏蔽线		
R.O.=Rated Output/额定输出 F.S.=Full Scale/满量程			

• Subject to change without notice / 如有更改,不另行通知

Customize torque sensor

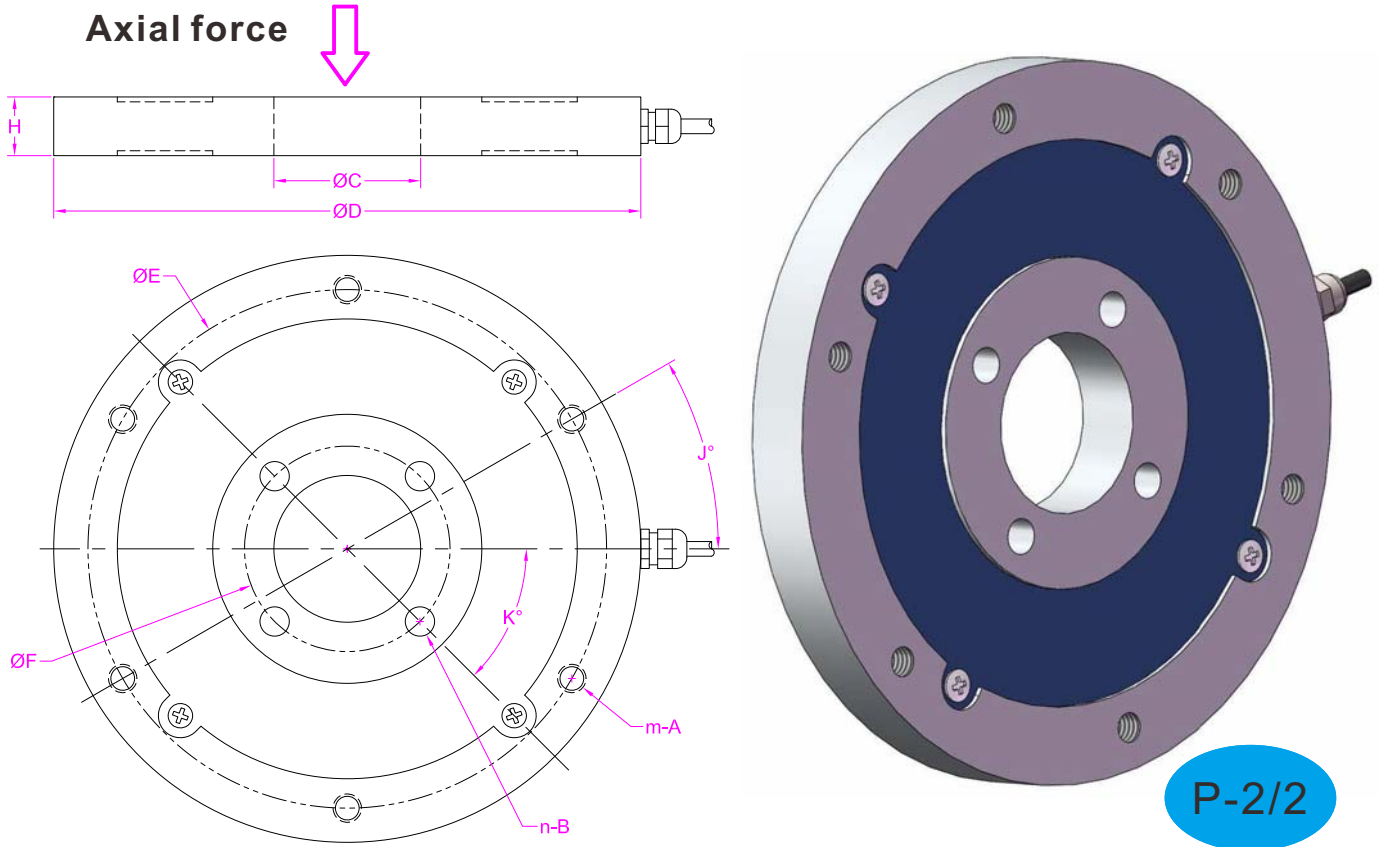

--- Main parameters ---

Torque range(NM)		Axial force(N)	
Qty of samples		Potential annual Qty	
A		m	
B		n	
C		D	
E		F	
H		J	
K		/	/
Other requirements			

- Dimensions in "milimeter".
- The Axial force may influence the design.
- A and B can be thru hole or threaded hole.
- m and n refers to the number of A and B.
- Please fill in the blank columns with a specific value or acceptable range.
- Customize upon given drawings is also available.