

Dimensions in "mm"

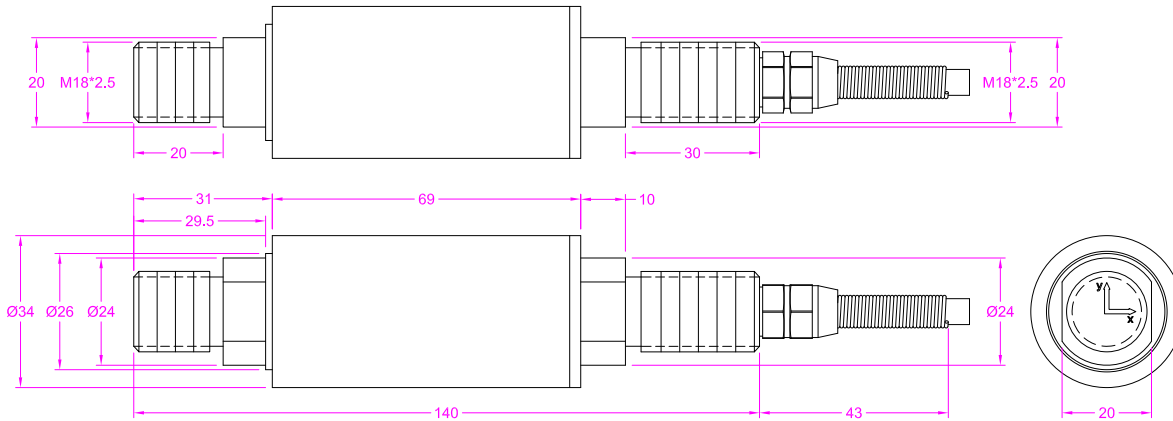

**Wiring Diagram**

**X-axis**

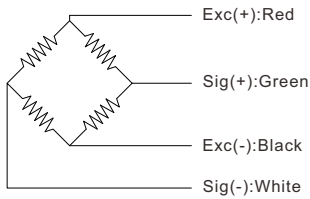

**Y-axis**

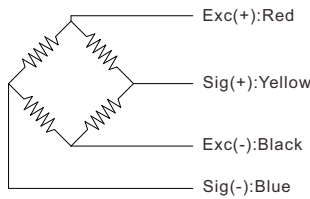

**Ordering Code:**

Part No.	Capacity
	Fx=Fy
F2H-20kg	20kg
F2H-50kg	50kg
F2H-100kg	100kg
F2H-200kg	200kg

--- Specifications / 规格参数 ---

Capacity/量程	Fx=Fy=20/50/100/200 kg		
Rated Output 额定输出	1.5 mV/V	Compensated Temp. 温度补偿范围	0...+40°C
Excitation 激励电压	3~12V	Operating Temp. 工作温度范围	-10...+60°C
Zero Balance 零点输出	±0.05mV/V	Temp. Shift Zero 零点温度漂移	±0.03% of R.O./°C
Nonlinearity 非线性	±0.2% of R.O.	Temp. Shift Span 灵敏度温度漂移	±0.02% of R.O./°C
Hysteresis 滞后	±0.2% of R.O.	Input Resistance 输入阻抗	180±30Ω
Nonrepeatability 非重复性	±0.1% of R.O.	Output Resistance 输出阻抗	350±10Ω
Creep(5min) 蠕变(5min)	±0.05% of R.O.	Insulation Resistance 绝缘阻抗	>2000MΩ(50V)
Safe Overload 安全过载	150% of F.S.	Ingress Protection 防护等级	IP50
Ultimate Overload 极限过载	200% of F.S.	Material of Element 弹性体材料	Stainless steel 不锈钢
Cable 导线	Ø5.8*2000mm 6-core shielded cable Ø5.8*2000mm 6芯屏蔽线		
R.O.=Rated Output/额定输出 F.S.=Full Scale/满量程			

• Subject to change without notice / 如有更改,不另行通知

## 2-Channel load cell amplifier LC2A

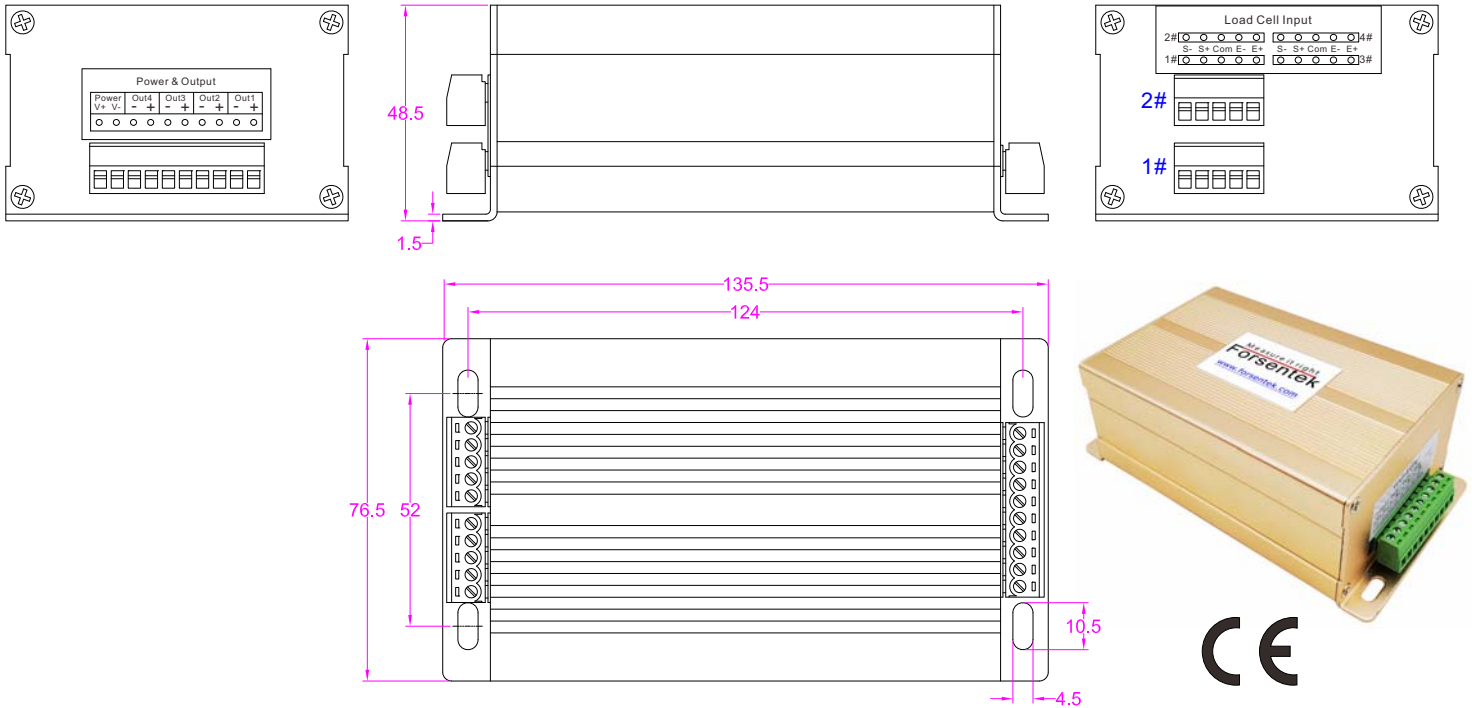

Ordering Code			
For compression only (Or tension only)		For tension and compression (Or clockwise and CCW)	
24V Power supply	12V Power supply	24V Power supply	12V Power supply
LC2A(0-3.3V)-24V	LC2A(0-3.3V)-12V	LC2A(0-2.5-5V)-24V	LC2A(0-2.5-5V)-12V
LC2A(0-5V)-24V	LC2A(0-5V)-12V	LC2A(0-5-10V)-24V	LC2A(0-5-10V)-12V
LC2A(0-10V)-24V	LC2A(0-10V)-12V	LC2A(-5-5V)-24V	LC2A(-5-5V)-12V
LC2A(0-20mA)-24V	LC2A(0-20mA)-12V	LC2A(-10-10V)-24V	LC2A(-10-10V)-12V
LC2A(4-20mA)-24V	LC2A(4-20mA)-12V	LC2A(4-12-20mA)-24V	LC2A(4-12-20mA)-12V

### --- Specifications / 规格参数 ---

Function/功能	Turn mV signal into V or mA signal 将mV信号放大成V或mA信号
Accuracy/精度	0.15%
Power supply/供电电压	24V DC or 12V DC
Excitation for load cell/传感器激励电压	5V DC
Input signal range/输入信号范围	0.6~3.0mV/V
Output signal/输出信号	Refer to ordering code
Working Temp./工作温度	-10...+60°C
Material of enclosure/外壳材料	Aluminum alloy/铝合金
Ingress protection/防护等级	IP40

• Subject to change without notice / 如有更改,不另行通知

P-2/4

Wiring example between F2H and amplifier LC2A

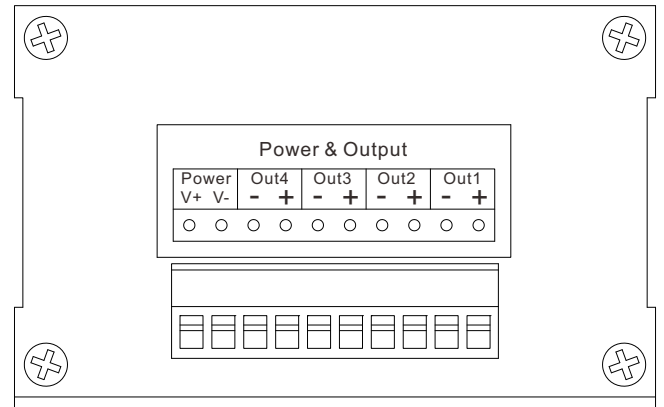
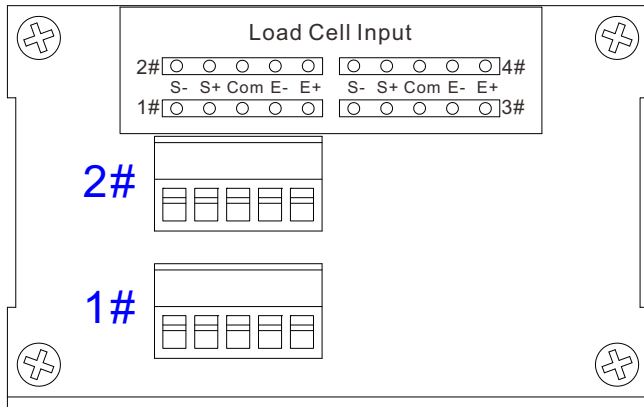
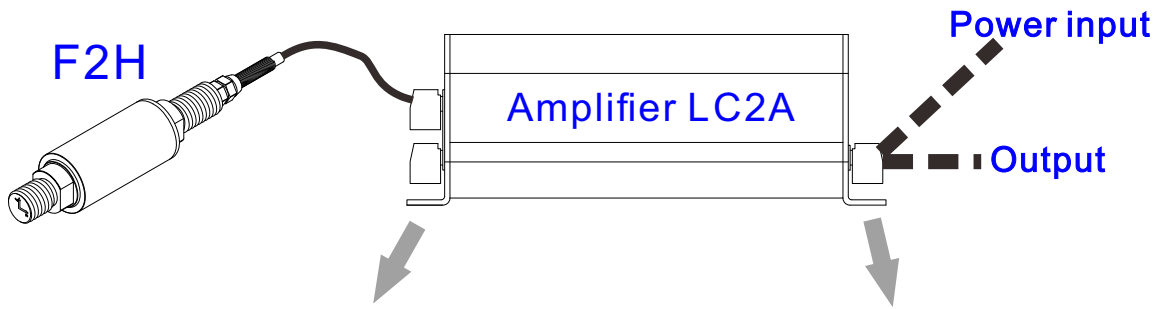

Wiring code

1# terminal connects with Fx channel			
E+	Red	E-	Black
S+	Green	S-	White
2# terminal connects with Fy channel			
S+	Yellow	S-	Blue

Power			
V+	Power+	V-	Power-
Out1 @ Fx output			
+	Output+	-	Output-
Out2 @ Fy output			
+	Output+	-	Output-

## Calibration instructions of F2H and LC2A

Before operation, clients need to prepare:

- 1-Power supply for LC2A
- 2-3 x 2-core cables for power input and signal output
- 3-Multimeter to measure the output signal from LC2A
- 4-Reference load and necessary tools for calibration
- 5-Screw drivers to open the cover plate of LC2A and adjust the potentiometers during calibration

### 1-Wiring(Refer to P-3/4)

### 2-Open the top cover plate of LC2A,you'll see below view:

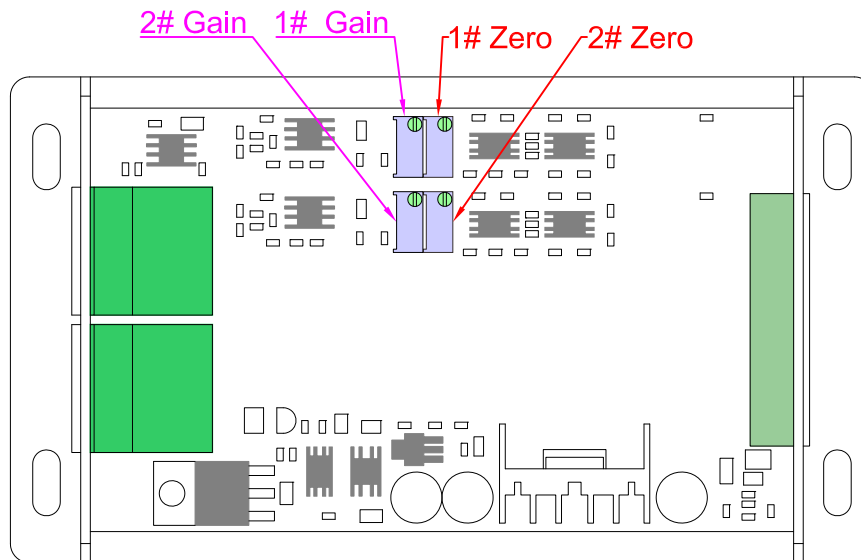

### 3-Calibration of Fx channel

- 3.1-Measuring the output signal from Out1 of LC2A using a multimeter.
- 3.2-Applying 0 load to Fx direction,adjust potentiometer “**1# Zero**” to get desired output.
- 3.3-Applying reference load to Fx direction,adjust potentiometer “**1# Gain**” to get desired output.
- 3.4-Repeat step 3.2 and 3.3 for 2-3 times to get better result.

### 4-Calibration of Fy channel

- 4.1-Measuring the output signal from Out2 of LC2A using a multimeter.
- 4.2-Applying 0 load to Fy direction,adjust potentiometer “**2# Zero**” to get desired output.
- 4.3-Applying reference load to Fy direction,adjust potentiometer “**2# Gain**” to get desired output.
- 4.4-Repeat step 4.2 and 4.3 for 2-3 times to get better result.

### 5-Install the top cover plate of LC2A